

Load Capacities up to 10,000kg

- Fully fabricated steel frames provide optimum strength and durability
- Swivel castors have a precision machined deep grooved ballrace
- Top plates conform to either ISO 2184 classes 5 or ISO class 6
- Grease nipples are fitted in the swivel race
- Bearings are sealed to accommodate the most severe operating conditions
- Directional Lock (suffix K) available on swivel castors
- Australian made
- 12 month warranty

Users include: Aircraft Service, Freight Handlers, Marine and Engineering Contractors

This range has been designed and built specifically for that severe heavy duty application where reliability is important.

The design also allows for power towing up to 16kph on smooth unobstructed surfaces. Recommended castors for this application are identified by a second capacity rating in the specifications table.

Castors to 2 Tonne Capacity Frames

Designed to include a precision machined and hardened deep-groove integral swivel race. This combines with fully welded legs from a generous steel selection for optimum strength.

The race is sealed, greasable and adjustable for any maintenance required in the long-term.

A ring-pull directional lock is available on swivel models.

The plate size conforms to international standard ISO class 5.

Wheels

The range includes an option of cast iron and two grades of polyurethane wheels, fitted with high capacity deep groove precision ball bearings. Diameters range from 150mm to 250mm.

Castors from 3 to 10 Tonne Capacity Frames

A fully fabricated heavy-duty frame coupled with a high tensile steel kingpin, ensure maximum strength and performance.

High capacity opposed tapered roller bearings ensure the swivel assembly action is ultra smooth. Bearings are sealed to accommodate the most severe operating conditions, and are adjustable if the need arises.

A ring-pull directional lock is available on swivel models.

The 3 and 5 tonne castor has a top plate that conforms to ISO class 5, while the 6 and 10 tonne castor conforms to ISO class 6.

Wheels

This super capacity range has large diameter wheels up to 400mm with either tapered or spherical roller bearings. Two polyurethane options are available to provide a greater capacity selection.

12 Month Warranty

This range carries our standard 12 month warranty against faulty workmanship and materials, and is backed by a service and parts network Australia wide.



super

CASTORS

WHEEL SPECIFICATIONS						CASTOR SPECIFICATIONS							
Dia 'A'	Width 'B'	Wheel Type	Wheel Model No.	Bearing	Capacity	Height 'C'	Swivel Model No.	Rigid Model No.	Swept Radius 'D'	Radius 'K'	Plate Code	Product Code Swivel	Product Code Rigid
150	75	Polyurethane/Cast Iron	LV6430	Prec Ball	1800	205	LV6431	LV6432	140	N/A	D	-	-
200	75	Cast Iron	L677	Prec Ball	2000	260	LV8531	LV8532	160	N/A	D	01066859	01067029
200	75	Polyurethane/Cast Iron	L855PU	Prec Ball	1000/750	260	LV8431-95A	LV8432-95A	160	N/A	D	-	-
200	75	Polyurethane/Cast Iron	L856PU	Prec Ball	2000/1000	260	LV8431	LV8432	160	N/A	D	01063153	01063068
250	75	Cast Iron	L682	Prec Ball	2000	310	LV10531	LV10532	190	N/A	D	01067454	01067590
250	75	Polyurethane/Cast Iron	L863PU	Prec Ball	2000/1300	310	LV10431	LV10432	190	N/A	D	01067097	01067318
250	100	Polyurethane/Cast Iron	L753PU	Prec Ball	3000/2000	370	LX10431	LX10432	195	N/A	D	-	-
250	100	Polyurethane/Cast Iron	L756PU	Prec Ball	5000/3000	370	L510PU	L511PU	195	N/A	D	01061776	01061861
300	75	Polyurethane/Cast Iron	L870PU	Prec Ball	2000/1300	364	LV12431	LV12432	220	N/A	D	01067692	01067845
300	100	Polyurethane/Cast Iron	L755PU	Taper	5000/3000	420	L500PU	L501PU	220	N/A	D	01061623	01061742
400	125	Polyurethane/Cast Iron	LY16450	Sph Roller	6000/4000	550	LY16451	LY16452	320	N/A	E	01067947	01068015
400 _{Twin}	125	Polyurethane/Cast Iron	LY16450	Sph Roller	10000/7000	570	LZ16451	LZ16452	350	N/A	E	01068134	01068202

Options

Directional Lock, use suffix K after the swivel model number - i.e. LV8431K

TECHNICAL SPECIFICATIONS

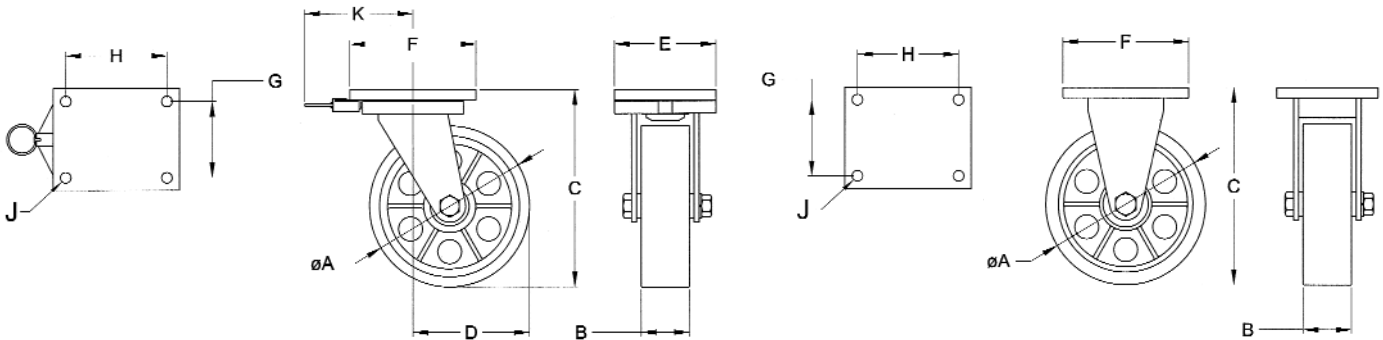

Top Plate Sizes and Bolt Hole Dimensions

All dimensions in millimetres

Plate Code	E x F	G x H	J
D	160 x 200	120 x 160	16
E	205 x 255	160 x 210	20



Models and specifications are subject to change without notice, all dimensions are nominal

Adelaide Tel: 08 8229 7800 Fax: 08 8445 1802
Brisbane Tel: 07 3217 0699 Fax: 07 3217 0822
Sydney Tel: 02 9648 3866 Fax: 02 9648 3599
Perth Tel: 08 9277 6999 Fax: 08 9331 1563
Melbourne Tel: 03 9548 9435 Fax: 03 9548 9460

